

Applications of Mathematics

Abdur Rashid; Shakaib Akram

Convergence of Fourier spectral method for resonant long-short nonlinear wave interaction

Applications of Mathematics, Vol. 55 (2010), No. 4, 337–350

Persistent URL: <http://dml.cz/dmlcz/140404>

Terms of use:

© Institute of Mathematics AS CR, 2010

Institute of Mathematics of the Czech Academy of Sciences provides access to digitized documents strictly for personal use. Each copy of any part of this document must contain these *Terms of use*.



This document has been digitized, optimized for electronic delivery and stamped with digital signature within the project *DML-CZ: The Czech Digital Mathematics Library* <http://dml.cz>

CONVERGENCE OF FOURIER SPECTRAL METHOD FOR
RESONANT LONG-SHORT NONLINEAR WAVE INTERACTION*

ABDUR RASHID, Dera Ismail Khan, SHAKAIB AKRAM, Lahore

(Received April 9, 2008)

Abstract. In this paper, the evolution equations with nonlinear term describing the resonance interaction between the long wave and the short wave are studied. The semi-discrete and fully discrete Crank-Nicholson Fourier spectral schemes are given. An energy estimation method is used to obtain error estimates for the approximate solutions. The numerical results obtained are compared with exact solution and found to be in good agreement.

Keywords: long-short wave interaction, Fourier spectral method, energy estimation method

MSC 2010: 65M70, 65M06

1. INTRODUCTION

The interaction phenomena between long waves and short waves has been studied in various physical situations. This phenomena are of interest in several fields of physics and fluid dynamics: an electron-plasma, ion-field interaction [8], diatomic lattice systems [13], and water wave theory [4]. The short wave is usually described by the Schrödinger type equation and the long wave is described by some sort of wave equation accompanied with dispersive term. In the theory of capillary-gravity waves, Kawahara et al. [5] studied the coupled system

$$(1.1) \quad i\partial_t S + ic_s \partial_x S + \partial_x^2 S - \alpha LS = 0,$$

$$(1.2) \quad \partial_t L + c_l \partial_x L + \partial_x^3 L + \partial_x(L^2) + \beta \partial_x(|S|^2) = 0,$$

*This work was supported by Higher Education Commission, Pakistan, under Grant No. 380.

where L and S describe long and short water waves, respectively, and α , β , c_s , and c_l are real constants. When the resonance condition $c_s = c_l$ holds, this equation is known as the coupled Schrödinger-KdV equation. The physical significance of (1.1)–(1.2) is that the dispersion of the short waves is balanced by the nonlinear interaction of the long waves with the short waves, while the evolution of the long waves is driven by the self interaction of the short waves. Here $\partial_x = \partial/\partial x$, $\partial_x^2 = \partial^2/\partial x^2$, $\partial_x^3 = \partial^3/\partial x^3$, and $\partial_t = \partial/\partial t$.

One of the closely related resonant interactions is described by the following system:

$$(1.3) \quad i\partial_t u(x, t) + \partial_x^2 u(x, t) - \alpha u(x, t)v(x, t) = 0, \quad t > 0, \quad x \in \mathbb{R},$$

$$(1.4) \quad \partial_t v(x, t) + \beta \partial_x (|u(x, t)|^2) = 0,$$

$$u(x, 0) = u_0(x), \quad v(x, 0) = v_0(x),$$

which was introduced by Benney [2] (see also Yajima-Oikawa [12] and Funakoshi-Oikawa [4]) and both the inverse scattering method ([12], [7]) and the theory of evolution equations ([1], [6], [10]) have been applied. Zhang Fayong and Xiang Xinmin [14] investigated the pseudospectral method for (1.3)–(1.4).

In this paper we consider a subclass of long-short wave interactions described by Benney's equation (1.3)–(1.4), namely the periodic initial boundary-value problem

$$(1.5) \quad i\partial_t u(x, t) + \partial_x^2 u(x, t) - \alpha u(x, t)v(x, t) = 0, \quad t > 0, \quad x \in [-L, L],$$

$$(1.6) \quad \partial_t v(x, t) + \beta \partial_x (|u(x, t)|^2) = 0, \quad t > 0, \quad x \in [-L, L],$$

$$(1.7) \quad u(x, 0) = u_0(x), \quad v(x, 0) = v_0(x), \quad x \in [-L, L],$$

$$(1.8) \quad u(x - L, t) = u(x + L, t), \quad v(x + L, t) = v(x - L, t), \quad t > 0, \quad x \in [-L, L].$$

We investigate the first order finite difference approximation in time, combined with Crank-Nicholson Fourier spectral scheme in space, for solving (1.5)–(1.8). Both the semi-discrete and the fully discrete schemes are analyzed and error estimations for both are found. The numerical results are presented, which checks the theoretical results. The rates of convergence of the resulting schemes are $O(N^{-S})$ and $O(\tau + N^{-S})$, where N is the number of spatial Fourier modes, τ is the discrete mesh spacing of the time variable t , and S depends only on the smoothness of the exact solution.

2. NOTATION

Let $\Omega = [-L, L]$, the inner product and the norm are defined by $(u, v) = \int_{\Omega} u(x)v(x) dx$ and $\|u\|^2 = (u, u)$, respectively. Let $\|u\|_{\infty} = \operatorname{ess\,sup}_{x \in \Omega} |u(x)|$ and let the periodic Sobolev spaces H_p^S be defined by

$$H_p^S(\Omega) = \{u \in H^S(\mathbb{R}) : u(x-L) = u(x+L)\}.$$

For any positive integer S , the Sobolev norm and semi-norm are defined by

$$\|u\|_S = \left(\sum_{j=0}^S \left\| \frac{\partial^j u}{\partial x^j} \right\|^2 \right)^{1/2}, \quad |u|_j = \left\| \frac{\partial^j u}{\partial x^j} \right\|^2.$$

We define

$$L^{\infty}(0, T; H_p^S(\Omega)) = \{u(\cdot, t) \in H_p^S(\Omega) : \sup_{0 \leq t < T} \|u(\cdot, t)\|_S < \infty\}.$$

For any even integer N , set $S_N = \operatorname{Span}\{\varphi_l = (1/\sqrt{2\pi})e^{i\pi lx/L} : |l| \leq N\}$. By P_N we denote the L^2 orthogonal projection operator of $H_p^S(\Omega)$ onto S_N . We define $x_l = -L + lh$ with $h = 2L/N$, where N is an even number of grid points.

For the discretization in the time variable t , let τ be the mesh spacing of t and $R_{\tau} = \{t = m\tau : 0 \leq m \leq [T/\tau]\}$, $u^m = u(x, m\tau)$. We use the following notation:

$$u_{Nt}^m = \frac{1}{\tau}[u_N^{m+1} - u_N^m], \quad v_{Nt}^m = \frac{1}{\tau}[v_N^{m+1} - v_N^m], \quad \hat{u}_N^m = \frac{1}{2}[u_N^{m+1} + u_N^m].$$

Lemma 1 ([9]). *For any periodic discrete function u^m ,*

$$(u_t^m, 2\hat{u}^m) = \frac{1}{\tau}(\|u^{m+1}\|^2 - \|u^m\|^2).$$

Lemma 2 ([3]). *Assume that $u \in H_p^S(\Omega)$. For any $0 \leq \mu \leq S$, there exists C independent of u and N such that*

$$\|u - P_N u\|_{\mu} \leq CN^{\mu-S} |u|_S.$$

Lemma 3 ([3], Inverse property). *Assume that $u \in S_N$. For any $0 \leq \mu \leq \sigma$, there exists C independent of u and N such that*

$$\|u\|_\sigma \leq CN^{\sigma-\mu} \|u\|_\mu.$$

3. ERROR ESTIMATION OF SEMI-DISCRETE SPECTRAL SCHEME

The semi-discrete spectral approximation of the problem (1.5)–(1.8) consists in finding $u_N, v_N \in S_N$, satisfying, for any $\psi \in S_N$,

$$(3.1) \quad (i\partial_t u_N + \partial_x^2 u_N - \alpha u_N v_N, \psi) = 0,$$

$$(3.2) \quad (\partial_t v_N + \beta \partial_x (|u_N|^2), \psi) = 0,$$

$$(3.3) \quad u_N(x, 0) = P_N u_0, v_N(x, 0) = P_N v_0.$$

Suppose that (u, v) are the solutions of (1.5)–(1.8) and (u_N, v_N) are the solutions of (3.1)–(3.3). Set

$$\begin{aligned} e_1 &= u - u_N = (u - P_N u) + (P_N u - u_N) = \xi_1 + \eta_1, \\ e_2 &= v - v_N = (v - P_N v) + (P_N v - v_N) = \xi_2 + \eta_2. \end{aligned}$$

By Lemma 2 and using $(\xi_l, \psi) = 0$, $l = 1, 2$, for all $\psi \in S_N$, we have

$$(3.4) \quad \|e_l\| \leq \|\xi_l\| + \|\eta_l\| \leq CN^{-S} + \|\eta_l\|, \quad l = 1, 2.$$

Taking the inner product of (1.5) with $\psi \in S_N$ implies that

$$(3.5) \quad (i\partial_t u + \partial_x^2 u - \alpha uv, \psi) = 0.$$

Subtracting (3.5) from (3.1) yields

$$(3.6) \quad (i\partial_t e_1 + \partial_x^2 e_1 - \alpha(uv - u_N v_N), \psi) = 0.$$

Note that

$$(\partial_x^2 e_1, \psi) = -(\partial_x e_1, \partial_x \psi).$$

Setting $\psi = \eta_1$ in (3.6) and taking the imaginary part, we get

$$(3.7) \quad \frac{1}{2} \frac{d}{dt} \|\eta_1\|^2 = \alpha \operatorname{Im}(uv - u_N v_N, \eta_1),$$

where Im denotes the imaginary part. Throughout this paper, we shall use C to denote a general positive constant independent of τ and N . It can be of different values in different cases. We have

$$|\alpha \text{Im}(uv - u_N v_N, \eta_1)| \leq |\alpha|(\|uv - u_N v_N\|^2 + \|\eta_1\|^2).$$

By applying Lemma 2, we obtain

$$\begin{aligned} \|uv - u_N v_N\| &= \|u(v - v_N) + v_N(u - u_N)\| \\ &\leq \|u\|_\infty \|v - v_N\| + \|v_N\|_\infty \|u - u_N\| \\ &\leq C(N^{-S} + \|\eta_2\| + \|\eta_1\|). \end{aligned}$$

Substituting the above estimate into (3.7), we obtain

$$(3.8) \quad \frac{1}{2} \frac{d}{dt} \|\eta_1\|^2 \leq C(N^{-2S} + \|\eta_1\|^2 + \|\eta_2\|^2).$$

On the other hand, taking the inner product of (1.6) with $\psi \in S_N$ implies that

$$(3.9) \quad (\partial_t v + \beta \partial_x(|u|^2), \psi) = 0.$$

Subtracting (3.2) from (3.9) implies that

$$(3.10) \quad (\partial_t e_2 + \beta \partial_x(|u|^2 - |u_N|^2), \psi) = 0.$$

Setting $\psi = \eta_2$ in (3.10), we obtain

$$(3.11) \quad \frac{1}{2} \frac{d}{dt} \|\eta_2\|^2 + (\beta \partial_x(|u|^2 - |u_N|^2), \eta_2) = 0.$$

The second term of (3.11) can be estimated as follows:

$$|\beta(\partial_x(|u|^2 - |u_N|^2), \eta_2)| \leq |\beta|(\|\partial_x(|u|^2 - |u_N|^2)\|^2 + \|\eta_2\|^2).$$

By applying Lemma 2, we obtain the following result

$$\begin{aligned} \|\partial_x(|u|^2 - |u_N|^2)\| &\leq (\|\bar{u}\|_\infty \|\partial_x u - \partial_x u_N\| + \|\partial_x \bar{u}\|_\infty \|u - u_N\| \\ &\quad + \|\partial_x \bar{u}_N\|_\infty \|\bar{u} - \bar{u}_N\| + \|u_N\|_\infty \|\partial_x \bar{u} - \partial_x \bar{u}_N\|) \\ &\leq C(N^{-S} + \|\eta_1\| + \|\partial_x \eta_1\|), \end{aligned}$$

where \bar{u} is the conjugate of u . Substituting the above estimate into (3.11), we get

$$(3.12) \quad \frac{1}{2} \frac{d}{dt} \|\eta_2\|^2 \leq C(N^{-2S} + \|\partial_x \eta_1\|^2 + \|\eta_1\|^2 + \|\eta_2\|^2).$$

Setting $\psi = \partial_t \eta_1$ in (3.6) and taking the imaginary parts yields

$$(3.13) \quad (\partial_t e_1, \partial_t \eta_1) = \alpha \operatorname{Im}(uv - u_N v_N, \partial_t \eta_1).$$

Using the Cauchy-Schwarz inequality and the algebraic inequality $ab \leq \varepsilon a^2 + (1/4\varepsilon)b^2$, we get

$$(3.14) \quad \|\partial_t \eta_1\|^2 \leq C(N^{-2S} + \|\eta_1\|^2 + \|\eta_2\|^2).$$

Now taking $\psi = \partial_t \eta_1$ in (3.6) and taking the real parts

$$(3.15) \quad \frac{1}{2} \frac{d}{dt} \|\partial_x \eta_1\|^2 = \alpha \operatorname{Re}(uv - u_N v_N, \partial_t \eta_1),$$

where Re denotes the real part, the equation (3.15) implies that

$$(3.16) \quad \frac{1}{2} \frac{d}{dt} \|\partial_x \eta_1\|^2 \leq C(N^{-2S} + \|\eta_1\|^2 + \|\partial_t \eta_1\|^2 + \|\eta_2\|^2).$$

Using (3.14), we can rewrite (3.16) as follows:

$$(3.17) \quad \frac{1}{2} \frac{d}{dt} \|\partial_x \eta_1\|^2 \leq C(N^{-2S} + \|\eta_1\|^2 + \|\eta_2\|^2).$$

Combining (3.8), (3.12), and (3.17), we get

$$(3.18) \quad \frac{1}{2} \frac{d}{dt} (\|\eta_1\|^2 + \|\partial_x \eta_1\|^2 + \|\eta_2\|^2) \leq C(N^{-2S} + \|\eta_1\|^2 + \|\partial_x \eta_1\|^2 + \|\eta_2\|^2).$$

Using the definition of Sobolev norm, we can rewrite (3.18) as follows:

$$(3.19) \quad \frac{1}{2} \frac{d}{dt} (\|\eta_1\|_1^2 + \|\eta_2\|^2) \leq C(N^{-2S} + \|\eta_1\|_1^2 + \|\eta_2\|^2).$$

Note that $\|\eta_1(0)\|_1 = \|\eta_2(0)\| = 0$, and by applying Gronwall's lemma, we obtain

$$\|\eta_1\|_1^2 + \|\eta_2\|^2 \leq CN^{-2S}.$$

Theorem 1. Suppose that $u_0(x), v_0(x) \in H^S(\Omega)$, $S \geq 1$. Assume that u and v are a solution of the equations (1.5)–(1.7). Then there exists a unique solution u_N, v_N of the spectral scheme (3.1)–(3.3). Moreover there exists a positive constant C independent of τ and N such that the following error estimate holds

$$\|u - u_N\|_1 + \|v - v_N\| \leq CN^{-S}.$$

4. ERROR ESTIMATION OF FULLY DISCRETE SPECTRAL SCHEME

The fully discrete Crank-Nicholson spectral scheme of the problem (1.5)–(1.8) consists in finding $u_N^m, v_N^m \in S_N$, satisfying for any $\psi \in S_N$,

$$(4.1) \quad (iu_{Nt}^m + \partial_x^2 \hat{u}_N^m - \alpha \hat{u}_N^m \hat{v}_N^m, \psi) = 0,$$

$$(4.2) \quad (v_{Nt}^m + \beta \partial_x (|\hat{u}_N^m|^2), \psi) = 0,$$

$$(4.3) \quad u_N^m(x, 0) = P_N u_0^m, \quad v_N^m(x, 0) = P_N v_0^m.$$

Set

$$e_1^m = u^m - u_N^m = (u^m - P_N u^m) + (P_N u^m - u_N^m) = \xi_1^m + \eta_1^m,$$

$$e_2^m = v^m - v_N^m = (v^m - P_N v^m) + (P_N v^m - v_N^m) = \xi_2^m + \eta_2^m.$$

By Lemma 2 and using $(\xi_l^m, \psi) = 0$, $l = 1, 2$ for all $\psi \in S_N$, we have

$$(4.4) \quad \|e_l^m\| \leq \|\xi_l^m\| + \|\eta_l^m\| \leq CN^{-S} + \|\eta_l^m\|, \quad l = 1, 2.$$

Substituting the solution $u(t_m), v(t_m)$ into (1.5)–(1.6), and subtracting (4.1) from (1.5) and (4.2) from (1.6), respectively, we have

$$(4.5) \quad (ie_{1t}^m + \partial_x^2 \hat{e}_1^m - \alpha(u^m v^m - \hat{u}_N^m \hat{v}_N^m), \psi) = (\tau_1^m, \psi),$$

$$(4.6) \quad (e_{2t}^m + \beta \partial_x (|u^m|^2 - |\hat{u}_N^m|^2), \psi) = (\tau_2^m, \psi),$$

where τ_1^m and τ_2^m are truncation errors given below

$$\tau_1^m = i(u_t^m - \partial_t u^m) + (\partial_x^2 \hat{u}^m - \partial_x^2 u^m) = \frac{\tau}{2} \partial_t^2 u(t_1^m) + \frac{\tau}{2} \partial_t \partial_x^2 u(t_2^m),$$

$$t \leq t_1^m, t_2^m \leq t + \tau,$$

$$\tau_2^m = (v_t^m - \partial_t v^m) = \frac{\tau}{2} \partial_t^2 v(t_3^m), \quad t \leq t_3^m \leq t + \tau.$$

Setting $\psi = 2\hat{\eta}_1^m$ in (4.5) and taking the imaginary parts, we have

$$(4.7) \quad \frac{1}{\tau} (\|\eta_1^{m+1}\|^2 - \|\eta_1^m\|^2) = \alpha \operatorname{Im}(u^m v^m - \hat{u}_N^m \hat{v}_N^m, 2\hat{\eta}_1^m) + (\tau_1^m, 2\hat{\eta}_1^m).$$

By applying the Cauchy-Schwarz inequality, we have

$$|\alpha \operatorname{Im}(u^m v^m - \hat{u}_N^m \hat{v}_N^m, 2\hat{\eta}_1^m)| \leq C(\|u^m v^m - \hat{u}_N^m \hat{v}_N^m\|^2 + \|\hat{\eta}_1^m\|^2).$$

But

$$u^m v^m - \hat{u}_N^m \hat{v}_N^m = u^m(v^m - \hat{v}^m) + \hat{v}^m(u^m - \hat{u}^m) + \hat{u}^m \hat{v}^m - \hat{u}_N^m \hat{v}_N^m.$$

By applying Lemma 2 and Taylor's theorem, we arrive at

$$\begin{aligned} \|\hat{u}^m \hat{v}^m - \hat{u}_N^m \hat{v}_N^m\| &\leq C(\|\eta_1^{m+1}\| + \|\eta_1^m\| + \|\eta_2^{m+1}\| + \|\eta_2^m\| + N^{-S} + \tau), \\ |(\tau_1^m, 2\hat{\eta}_1^m)| &\leq C(\|\eta_1^{m+1}\|^2 + \|\eta_1^m\|^2 + \tau^2). \end{aligned}$$

Substituting the above estimates into (4.7), we have

$$\begin{aligned} \frac{1}{\tau}(\|\eta_1^{m+1}\|^2 - \|\eta_1^m\|^2) &\leq C(\|\eta_1^{m+1}\|^2 + \|\eta_1^m\|^2 + \|\eta_2^{m+1}\|^2 + \|\eta_2^m\|^2 + \tau^2 + N^{-2S}), \\ \|\eta_1^{m+1}\|^2 &\leq \frac{1+C\tau}{1-C\tau}\|\eta_1^m\|^2 + C\tau(\|\eta_2^{m+1}\|^2 + \|\eta_2^m\|^2) + C(\tau^2 + N^{-2S}). \end{aligned}$$

Summing up the above equation for $m = 0$ to n , we find that

$$(4.8) \quad \|\eta_1^{n+1}\|^2 \leq C(\|\eta_1^0\|^2 + \tau \sum_{m=0}^n (\|\eta_2^m\|^2) + \tau^2 + N^{-2S}).$$

Setting $\psi = 2\hat{\eta}_2^m$ in (4.6), we get

$$(4.9) \quad \frac{1}{\tau}(\|\eta_2^{m+1}\|^2 - \|\eta_2^m\|^2) = \beta(\partial_x(|u^m|^2 - |\hat{u}_N^m|^2), 2\hat{\eta}_2^m) + (\tau_2^m, 2\hat{\eta}_2^m).$$

But

$$\partial_x |u^m|^2 - \partial_x |\hat{u}_N^m|^2 = (\partial_x |u^m|^2 - \partial_x |\hat{u}^m|^2) + (\partial_x |\hat{u}^m|^2 - \partial_x |\hat{u}_N^m|^2).$$

By applying Lemma 2 and Taylor's theorem, we obtain

$$\begin{aligned} \|\partial_x |u^m|^2 - \partial_x |\hat{u}_N^m|^2\| &\leq C(\tau + N^{-S} + \|\partial_x \eta_1^{m+1}\| + \|\partial_x \eta_1^m\|), \\ |(\tau_2^m, 2\hat{\eta}_2^m)| &\leq C(\tau^2 + \|\eta_2^{m+1}\|^2 + \|\eta_2^m\|^2). \end{aligned}$$

Substituting the above estimate into (4.9), we get

$$\begin{aligned} \frac{1}{\tau}(\|\eta_2^{m+1}\|^2 - \|\eta_2^m\|^2) &\leq C(\|\partial_x \eta_1^{m+1}\|^2 + \|\partial_x \eta_1^m\|^2 + \|\eta_2^{m+1}\|^2 + \|\eta_2^m\|^2 + \tau^2 + N^{-2S}), \\ \|\eta_2^{m+1}\|^2 &\leq \frac{1+C\tau}{1-C\tau}\|\eta_2^m\|^2 + C\tau(\|\partial_x \eta_1^{m+1}\|^2 + \|\partial_x \eta_1^m\|^2) + C(\tau^2 + N^{-2S}). \end{aligned}$$

Summing up the above equation for $m = 0$ to n , we get

$$(4.10) \quad \|\eta_2^{n+1}\|^2 \leq C(\|\eta_2^0\|^2 + \tau \sum_{m=0}^n (\|\partial_x \eta_1^m\|^2) + \tau^2 + N^{-2S}).$$

Letting $\psi = \eta_{1t}^m$ in (4.5) and taking the imaginary parts, we obtain

$$(e_{1t}^m, \eta_{1t}^m) - \alpha(u^m v^m - \hat{u}_N^m \hat{v}_N^m, \eta_{1t}^m) = (\tau_1^m, \eta_{1t}^m).$$

By using Lemma 2 and Taylor's theorem, we come to

$$(4.11) \quad \|\eta_{1t}^m\|^2 \leq C(\|\eta_1^{m+1}\|^2 + \|\eta_1^m\|^2 + \|\eta_2^{m+1}\|^2 + \|\eta_2^m\|^2 + \tau^2 + N^{-2S}).$$

Letting $\psi = 2\eta_{1t}^m$ in (4.5), and taking the real parts, we get

$$2(\partial_x^2 \hat{e}_1^m, \eta_{1t}^m) + 2\alpha \operatorname{Re}(u^m v^m - \hat{u}_N^m \hat{v}_N^m, \eta_{1t}^m) + (\tau_1^m, 2\eta_{1t}^m) = 0.$$

Again by applying Lemma 2 and Taylor's theorem, we find that

$$(4.12) \quad \frac{1}{\tau} (\|\partial_x \eta_1^{m+1}\|^2 - \|\partial_x \eta_1^m\|^2) \leq C(\|\eta_1^{m+1}\|^2 + \|\eta_1^m\|^2 + \|\eta_2^{m+1}\|^2 + \|\eta_2^m\|^2 + \|\eta_{1t}^m\|^2 + \tau^2 + N^{-2S}).$$

Using (4.11), we can rewrite (4.12) as follows:

$$(4.13) \quad \frac{1}{\tau} (\|\partial_x \eta_1^{m+1}\|^2 - \|\partial_x \eta_1^m\|^2) \leq C(\|\eta_1^{m+1}\|^2 + \|\eta_1^m\|^2 + \|\eta_2^{m+1}\|^2 + \|\eta_2^m\|^2 + \tau^2 + N^{-2S}).$$

Summing up (4.13) for $m = 0$ to n , we obtain

$$(4.14) \quad \|\partial_x \eta_1^{n+1}\|^2 \leq C(\|\partial_x \eta_1^0\|^2 + \tau \sum_{m=0}^n (\|\eta_1^m\|^2 + \|\eta_2^m\|^2) + \tau^2 + N^{-2S}).$$

Combining (4.8), (4.10), and (4.14), we get

$$\begin{aligned} E^n &= \|\eta_1^{n+1}\|^2 + \|\partial_x \eta_1^{n+1}\|^2 + \|\eta_2^{n+1}\|^2 \\ &\leq C(\|\eta_1^0\|^2 + \|\partial_x \eta_1^0\|^2 + \|\eta_2^0\|^2 + \tau^2 + N^{-2S}) \\ &\quad + C\tau \sum_{m=0}^n (\|\eta_1^m\|^2 + \|\partial_x \eta_1^m\|^2 + \|\eta_2^m\|^2). \end{aligned}$$

Using the definition of the Sobolev norm, we can rewrite the above equation as follows:

$$\begin{aligned} E^n &= \|\eta_1^{n+1}\|_1^2 + \|\eta_2^{n+1}\|^2 \\ &\leq C(\|\eta_1^0\|_1^2 + \|\eta_2^0\|^2 + \tau^2 + N^{-2S}) + C\tau \sum_{m=0}^n (\|\eta_1^m\|_1^2 + \|\eta_2^m\|^2), \end{aligned}$$

and hence

$$(4.15) \quad E^n \leq C(\tau^2 + N^{-2S} + \|\eta_1^0\|_1^2 + \|\eta_2^0\|^2) + C\tau \sum_{m=0}^n E^{m-1}.$$

Note that $\|\eta_1^0\|_1 = \|\eta_2^0\| = 0$, therefore equation (4.15) can be written as

$$(4.16) \quad E^n \leq C(\tau^2 + N^{-2S}) + C\tau \sum_{m=0}^n E^{m-1}.$$

By applying Gronwall's lemma, we obtain

$$C(\tau^2 + N^{-2S}) \leq Me^{-cT},$$

and so the estimate for E^n in (4.16) takes the form

$$E^n(t) \leq C(\tau^2 + N^{-2S})e^{c(n+1)\tau} \quad \forall (n+1)\tau \leq T.$$

Thus we have proved:

Theorem 2. *Assume that u^m, v^m are solutions of the equations (1.5)–(1.8) and u_N^m, v_N^m are solutions of the spectral scheme (4.1)–(4.3), respectively. Then there exists a positive constant M , independent of τ and N , such that the following error estimate holds*

$$\sup_{1 \leq m \leq [T/\tau]} (\|u^m - u_N^m\|_1 + \|v^m - v_N^m\|) \leq M(\tau + N^{-S}).$$

5. NUMERICAL RESULTS

In this section we present some numerical results to demonstrate the computational complexity of the Fourier spectral method for (1.5)–(1.8). All computations in this section were carried in FORTRAN 90 and all figures are obtained by using MATLAB 6.5 on Compaq Branded system, Processor 3.2 GHz, Memory 1 GB, Hard Disk 80 GB.

The explicit and exact periodic wave solutions of resonant long-short nonlinear wave interaction of (1.5)–(1.8) is given by [11]:

$$(5.1) \quad u(x, t) = \pm \sqrt{\frac{1-w^2}{\beta}} 2i \operatorname{sech}(2\eta(x-wt)) \exp\left[i\left(\frac{w}{2}x - \left(\frac{w^2}{4} - 4\eta^2\right)t\right)\right],$$

$$(5.2) \quad v(x, t) = -\frac{1-w^2}{\beta} 4\eta^2 \operatorname{sech}^2(2\eta(x-wt)) + \alpha,$$

where w , η and α are positive constants.

The relative discrete L^2 -norm error is defined as follows:

$$(5.3) \quad E_2(\mathbf{u}(t)) = \left[\frac{\sum_{x \in \Omega} |\mathbf{u}(x, t) - \mathbf{u}_N(x, t)|^2}{\sum_{x \in \Omega} |\mathbf{u}(x, t)|^2} \right]^{1/2},$$

where $\mathbf{u} = (u, v)$ is the exact solution of the equation (1.5)–(1.8) and $\mathbf{u}_N = (u_N, v_N)$ is the solution of the Crank-Nicholson Fourier spectral scheme (4.1)–(4.3).

The calculation is carried out with $\alpha = 1.0$, $\beta = 1.0$, $\eta = 0.5$, $w = 0.5$, and $L = 16$ throughout the computation. For comparison, we consider the pseudospectral scheme of [14]. In Tab. 1 the numerical results show that the present scheme (4.1)–(4.3) gives much better results than the scheme [14]. The present scheme provides the numerical solution with high accuracy even if N is small. In order to check the rate of convergence of the present scheme, Tab. 2 shows the numerical results of the present scheme. We obtained that if N increases and τ decreases proportionally, then the errors become smaller quickly, which shows the convergence of the present scheme.

Time	$E_2(u(t))$		$E_2(v(t))$	
	Present scheme	Scheme [14]	Present scheme	Scheme [14]
$t = 0.2$	$0.9212E-5$	$0.9508E-4$	$0.1231E-5$	$0.3214E-4$
$t = 0.4$	$0.5916E-5$	$0.6527E-4$	$0.4346E-5$	$0.3565E-4$
$t = 0.6$	$0.1529E-4$	$0.1395E-3$	$0.8666E-4$	$0.7689E-3$
$t = 0.8$	$0.3829E-4$	$0.3646E-3$	$0.1364E-4$	$0.2478E-3$
$t = 1.0$	$0.6612E-4$	$0.6310E-3$	$0.1883E-4$	$0.2985E-3$

Table 1. Comparison of errors at $N = 8$, $\tau = 0.001$.

N	$E_2(u(t))$			$E_2(v(t))$		
	$\tau = 0.005$	$\tau = 0.001$	$\tau = 0.0005$	$\tau = 0.005$	$\tau = 0.001$	$\tau = 0.0005$
4	$0.3832E-3$	$0.6309E-3$	$0.7667E-3$	$0.2163E-3$	$0.2667E-3$	$0.8263E-3$
8	$0.3785E-5$	$0.4218E-6$	$0.3258E-7$	$0.3491E-5$	$0.3168E-6$	$0.5454E-7$
16	$0.3808E-5$	$0.4363E-6$	$0.4987E-7$	$0.3573E-5$	$0.3545E-6$	$0.5578E-7$
32	$0.3979E-5$	$0.5364E-6$	$0.5153E-7$	$0.3684E-5$	$0.4667E-6$	$0.6581E-7$
64	$0.3989E-5$	$0.5365E-6$	$0.5265E-7$	$0.3795E-5$	$0.4788E-6$	$0.6591E-7$
128	$0.3999E-5$	$0.5367E-6$	$0.5376E-7$	$0.3856E-5$	$0.4897E-6$	$0.6681E-7$

Table 2. The relative errors for u and v at $t = 1.0$.

At time $t = 1.0$, the single soliton is plotted in Fig. 1. The surface graphs of the exact solution and the approximate solution at $t = 1$ are given in Fig. 2 and Fig. 3, respectively. We observe that the behavior of the exact solution and the approximate solution are the same.

A clear conclusion can be drawn from the numerical results that Crank-Nicholson Fourier spectral scheme provides highly accurate solution in spatial discretization for nonlinear partial differential equations. It is also worth noting the advantage of the spectral methodology that it displays a fast convergence of the solution by using Fast Fourier Transform.

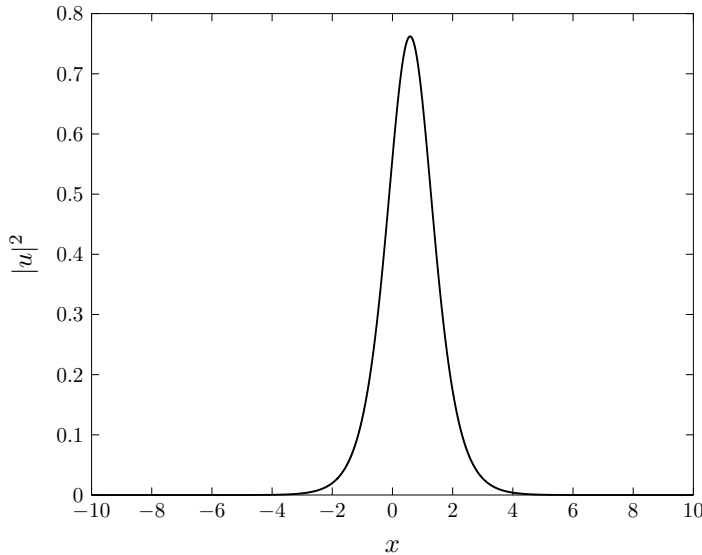
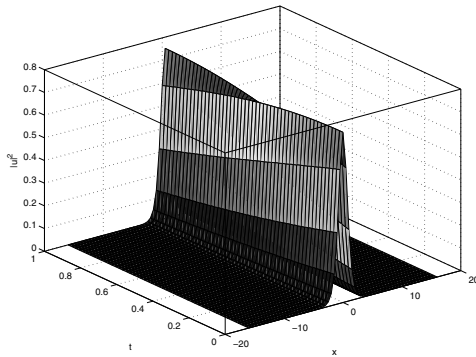
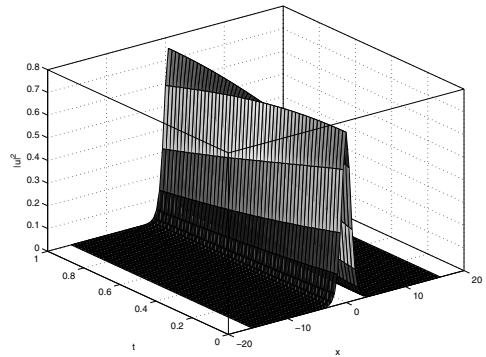

Figure 1. Plot of the soliton at $t = 1.0$.



Exact solution of u .



Approx. solution of u .

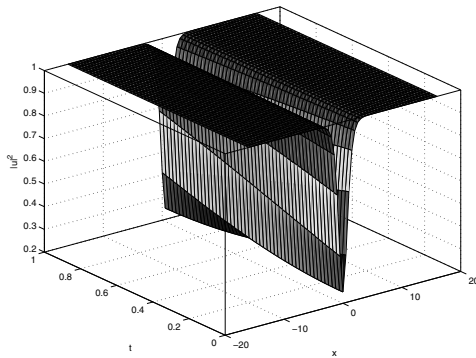

Exact solution of v .

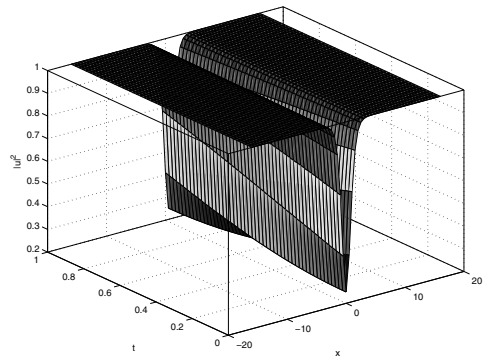

Approx. solution of v .

Figure 2. Comparison of exact solution and approximate solution of u and v .

References

- [1] *D. Bekiranov, T. Ogawa, G. Ponce*: On the well-posedness of Benney's interaction equation of short and long waves. *Adv. Differ. Equ.* *6* (1996), 919–937.
- [2] *D. J. Benney*: A general theory for interactions between short and long waves. *Studies Appl. Math.* *56* (1977), 81–94.
- [3] *C. Canuto, M. Y. Hussaini, A. Quarteroni, T. A. Zang*: *Spectral Methods in Fluid Dynamics*. Springer, Berlin, 1988.
- [4] *M. Funakoshi, M. Oikawa*: The resonant interaction between a long internal gravity wave and a surface gravity wave packet. *J. Phys. Soc. Japan* *52* (1983), 1982–1995.
- [5] *T. Kawahara, N. Sugimoto, T. Kakutani*: Nonlinear interaction between short and long capillary-gravity waves. *J. Phys. Soc. Japan* *39* (1975), 1379–1386.
- [6] *Ph. C. Lauren*: On a nonlinear Schrödinger equation arising in the theory of water waves. *Nonlinear Anal., Theory Methods Appl.* *24* (1995), 509–527.
- [7] *Y. C. Ma*: The complete solution of the long-wave-short-wave resonance equations. *Stud. Appl. Math.* *59* (1978), 201–221.

- [8] *K. Nishikawa, H. Hojo, K. Mima, H. Ikezi*: Coupled nonlinear electron-plasma and ion acoustic waves. *Phys. Rev. Lett.* *33* (1974), 148–151.
- [9] *A. Quarteroni, A. Valli*: Numerical approximation of partial differential equations. Springer Series in Computational Mathematics. Springer, Berlin, 1997.
- [10] *M. Tsutsumi*: Well-posedness of the Cauchy problem for a coupled Schrödinger-KdV equation. *Math. Sci. Appl.* *2* (1993), 513–528.
- [11] *S. Yadong*: Explicit and exact solutions for a generalized long-short wave resonance equations with strong nonlinear term. *Chaos Solitons Fractals* *26* (2005), 527–539.
- [12] *N. Yajima, M. Oikawa*: Formation and interaction of sonic Longmuir soliton. *Prog. Theor. Phys.* *56* (1974), 1719–1739.
- [13] *N. Yajima, J. Satsuma*: Soliton solutions in a diatomic lattice system. *Prog. Theor. Phys.* *62* (1979), 370–37.
- [14] *F. Zhang, X. Xinmin*: Pseudospectral method for a class of system of LS wave interaction. *Numer. Math. Nanjing* *12* (1990), 199–214.

Authors' addresses: *A. Rashid*, Department of Mathematics, Gomal University, Dera Ismail Khan, Pakistan, e-mail: rashid_himat@yahoo.com; *S. Akram*, Department of Mathematics, COMSATS Institute of Information Technology, Defence Road, Off Raiwind Road, Lahore, Pakistan.