

Jan Štecha

Robust and nonrobust tracking

Kybernetika, Vol. 34 (1998), No. 2, [203]--216

Persistent URL: <http://dml.cz/dmlcz/135200>

Terms of use:

© Institute of Information Theory and Automation AS CR, 1998

Institute of Mathematics of the Academy of Sciences of the Czech Republic provides access to digitized documents strictly for personal use. Each copy of any part of this document must contain these

Terms of use.



This paper has been digitized, optimized for electronic delivery and stamped with digital signature within the project *DML-CZ: The Czech Digital Mathematics Library*
<http://project.dml.cz>

ROBUST AND NONROBUST TRACKING¹

JAN ŠTECHA

For zero steady state tracking error it is necessary to include n integrators in the control loop in the case of reference signal generated by n integrators. This result can be generalized to arbitrary n unstable modes of the reference generator according to the “internal model principle”. This paper shows an alternative solution of the asymptotic reference signal tracking problem using feedforward. The solution is not robust but gives a feedback controller with reduced complexity.

Robust tracking structure with error driven controller and nonrobust control structure with feedforward are also compared with respect to quadratic criteria. The alternative solution with feedforward is not asymptotically robust but sometimes gives better performance with respect to quadratic criteria.

1. INTRODUCTION

It is well known that for step reference asymptotic tracking (zero steady state control error) it is necessary to have one integrator in the control loop.

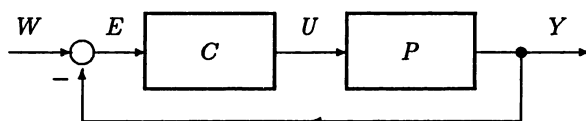

Fig. 1. Asymptotic step reference tracking by the integrator in the controlled plant P or in the controller C .

This integrator can be either in the plant (astatic plant) or in the controller (controller with integrator part, such as PID controller) – see Figure 1. This approach can be generalized according to “internal model principle” [6] which states that all unstable modes to be followed must be in the plant or in the controller. In such

¹This work has been supported by the Grant Agency of the Czech Republic under grant 102/97/0861, by the Grant Agency of the Academy of Sciences of the Czech Republic under grant A 2147701, and by the Ministry of Education of Czech Republic under project VS 97/034. Part of the results were presented at the IASTED International Conferences in Cairo (1995) and Innsbruck (1996).

case the control error E is approaching to zero for time $t \rightarrow \infty$. Asymptotic step reference tracking realized by the integrator in the control loop is robust in the sense that it does not depend on the dynamic properties of the plant and the controller provided that the control loop is asymptotically stable.

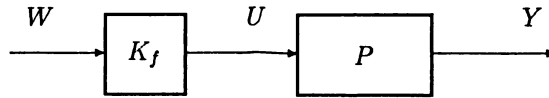

Fig. 2. Asymptotic step reference tracking by the unit gain.

Another possibility for asymptotic step reference tracking is to guarantee unit gain between reference input and plant output (plant controlled variable) – see Figure 2. Feedforward amplifier gain K_f equals $K_f = \frac{1}{K}$, where K is the plant gain (provided it is finite). Step reference tracking realized in such a way is not robust because it is realized in open loop. The plant must be stable in case of open loop control.

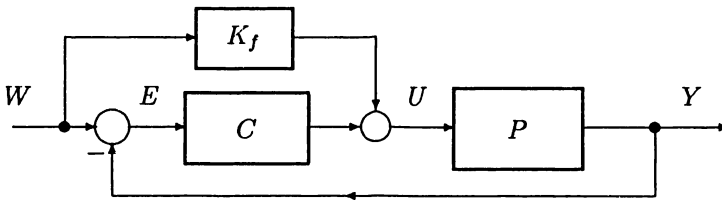

Fig. 3. Asymptotic ramp reference tracking by only one integrator in the controller C .

So there are two possibilities for the realization of step reference asymptotic tracking. Both control schemes are standard and are mentioned in [2]. In [3] and [4] it is shown that when these two control structures are realized simultaneously (as in Figure 3), such feedback structure gives zero steady state error not only for step reference, but also for the ramp reference.

In the paper it is shown how this approach can be generalized for polynomial reference tracking and disturbance rejection. Simulation results show how the quality of control with simple controller is influenced in these two control structures.

In the next sections discrete time robust and nonrobust LQ tracking is analyzed. For robust control structure it is sometimes necessary to pay in control quality. Comparison of these two discrete time control structures is analyzed in the last section together with the simulation results.

2. ASYMPTOTIC REFERENCE TRACKING

Step reference asymptotic tracking can be realized either by integrator in control loop or by feedforward controller which guarantee unit gain between reference and plant input. When these two control structures are realized simultaneously (as in Figure 3), such feedback structure gives zero steady state error not only for step reference, but also for the ramp reference. This statement is now proved for more

general case. According to this statement it is necessary to modify "internal model principle" for multiple poles of the reference signal.

It can be shown that the control structure according to Figure 3 can be used for polynomial reference tracking with less integrators in the control loop than usual. Let the reference signal $w(t)$ be equal to the i th order polynomial, so $w(t) = w_0 + w_1t + w_2t^2 + \dots + w_it^i$. For robust reference tracking according to Figure 1 the controller C must have $i + 1$ integrators. But only i integrators in the control loop according to Figure 3 are necessary for such reference asymptotic tracking.

For asymptotic ramp reference tracking two integrators in control loop must be realized. Such control loop is difficult to stabilize. Control scheme for ramp reference tracking according to Figure 3 has only one integrator in the control loop.

Laplace transform of the reference polynomial $w(t)$ of the order i equals

$$W(s) = \frac{1}{s^{i+1}} \frac{g(s)}{f(s)},$$

where $g(s)$, $f(s)$ are numerator and denominator polynomials with nonzero absolute terms, denominator $f(s)$ is stable. The transfer function of the controller C with i integrators

$$C = \frac{1}{s^i} \frac{q(s)}{p(s)},$$

where $q(s)$, $p(s)$ are numerator and denominator polynomials with nonzero absolute terms. Transfer function of the plant is

$$P(s) = K_p \frac{b(s)}{a(s)},$$

where K_p is the gain of the plant and $b(s)$, $a(s)$ are numerator and denominator polynomials with unit absolute terms $b(0) = a(0) = 1$.

According to Figure 3 the control error equals

$$E(s) = W(s) - Y(s) = (1 - F_{w/y})W(s) = \left(1 - \frac{K_f P(s) + C(s)P(s)}{1 + C(s)P(s)}\right) W(s).$$

After the substitution for the plant, controller and reference, the control error

$$E(s) = \left(1 - \frac{K_f K_p \frac{b(s)}{a(s)} + \frac{q(s)}{s^i p(s)} K_p \frac{b(s)}{a(s)}}{1 + \frac{q(s)}{s^i p(s)} K_p \frac{b(s)}{a(s)}}\right) \frac{g(s)}{s^{i+1} f(s)} = \frac{s^i p(a - K_f K_p b)g}{s^{i+1} \Delta f},$$

where $\Delta(s) = s^i q(s)a(s) + K_p q(s)b(s)$ is the characteristic polynomial of feedback structure. Because $K_f K_p = 1$ and $a(0) = b(0)$ the difference of the plant denominator and the plant numerator polynomials can be expressed in the form $a(s) - K_f K_p b(s) = a(s) - b(s) = sm(s)$ for some polynomial $m(s)$. So the controlled error has the form

$$E(s) = \frac{p(s)m(s)g(s)}{f(s)\Delta(s)}.$$

There is no zero pole in $E(s)$. Provided that the feedback loop is stable the steady state error equals zero ($\lim_{t \rightarrow \infty} e(t) = 0$).

So we have proved that asymptotic tracking of the polynomial reference of the i th order can be realized in control structure according to Figure 3 where controller C has only i integrators and feedforward gain K_f is adjusted in such a way that unit gain $K_f K_p = 1$ is guaranteed. It is a pleasant property of the control structure in Figure 3.

The same approach can be used for asymptotic elimination of measurable disturbance $v(t)$.

For discrete time control the same principle can be used. For ramp reference sequence tracking the discrete time controller C must have two unit poles in robust control structure and only one unit pole in nonrobust control structure (continuous integrator is changed to discrete summator).

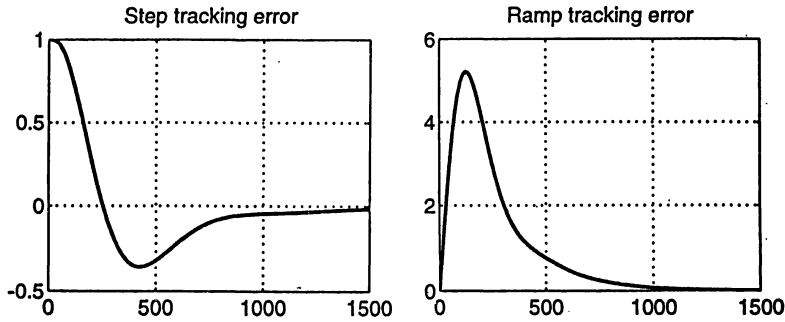

Fig. 4. Tracking errors for robust control structure.

Example. The quality of two control structures according to Figure 1 and Figure 3 is compared in this example. The dynamic properties of the superheater of the steam boiler on the corresponding 500 MW electric power level is described by the third order system with unit gain and equal time constants $T_i = 30s$ [4]. The plant transfer function equals

$$P(s) = \frac{1}{(1 + 30s)^3}.$$

For ramp reference tracking according to Figure 1 the controller C has the transfer function

$$C = K_c \frac{1 + T_c s}{s^2}.$$

The controller C must have at least one zero $\nu = -\frac{1}{T_c}$ where $T_c > T$ to be able to stabilize the control loop. For $T_c = 20T = 600s$ the acceleration constant K_c of the controller is adjusted in such a way that the crossover frequency ω_0 equals $\omega_0 = 2\frac{1}{T_c} = 0.0066s^{-1}$. The phase margin γ is approximately $\gamma = 30^\circ$. Tracking errors for step and ramp responses in such control structure are depicted in Figure 4.

On the contrary the control structure according to Figure 3 has $K_f = 1$ and only one integrator in the controller, so $C = \frac{K_c}{s}$ and no zero is necessary for stabilization. The crossover frequency in such case is at least two times greater, and this control structure has better dynamic properties. Tracking errors for step and ramp responses are depicted in Figure 5.

Continuous time approach was chosen in this section because we analyzed control structures with simple controllers – see PI or PII controllers in the previous example. Now most control problems are realized by discrete time controllers, so in the next two sections discrete time robust and nonrobust tracking is analyzed. Comparison of these two discrete time control structures is analyzed in the last section together with the simulation results.

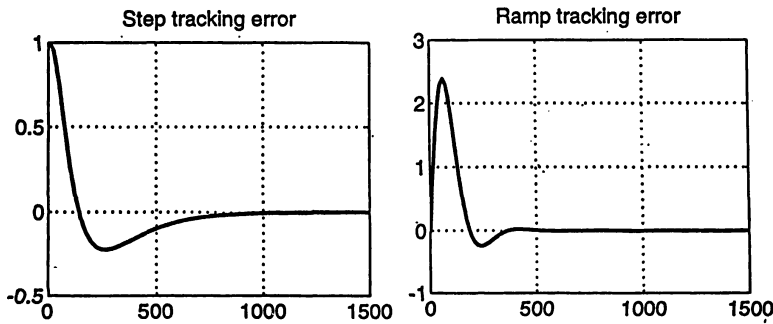

Fig. 5. Tracking errors for non-robust control structure.

3. NONROBUST LQ TRACKING

Nonrobust tracking control structure with feedforward according to Figure 3 can be generalized to two degree of freedom control structure according to Figure 6. The controller R consists of feedforward and feedback blocks with transfer functions $C_1 = \frac{s(d)}{p(d)}$ and $C_2 = \frac{q(d)}{p(d)}$. The nominator and denominator polynomials $q(d)$, $s(d)$ and $p(d)$ will be determined by an optimization procedure. The delay operator d is further omitted for simplification. So all polynomials are considered in delay operator d .

According to Figure 6 the control error equals

$$E(d) = W(d) - Y(d) = \frac{g}{f} - \frac{sbg}{\Delta f} = \frac{g(ap + b(q - s))}{f\Delta}, \tag{1}$$

where $\Delta = ap + bq$ is the characteristic polynomial of the feedback structure and

$$\frac{a}{f} = \frac{a^0}{f^0},$$

where a^0 and f^0 are coprime polynomials. Factorization of the polynomial f^0 gives

$$f^0 = (f^0)^+(f^0)^-,$$

where $(f^0)^+$ is the stable part of f^0 .

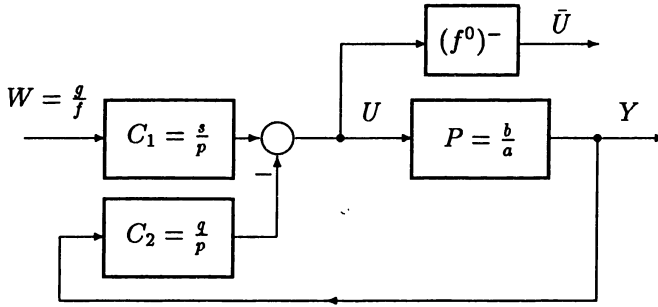

Fig. 6. Nonrobust structure for asymptotic reference tracking.

The control quality is measured by the quadratic criterion in the form

$$J = \sum_{k=0}^{\infty} e(k)^2 + r\bar{u}(k)^2. \quad (2)$$

When the polynomial f^0 is unstable (unstable modes of the reference which are not in the plant) the input U of the plant is unstable too and so the signal \bar{U} is considered in the criterion of control quality (see Figure 6). The constant r is the weight of control signal in the criterion and serves as tuning parameter of the optimal controller.

We are looking for the optimal controller R which minimizes the quadratic criterion (2). Such form of control quality criterion depends on initial conditions in the plant, controller and reference signal generator. If we have no direct access to the state of plant, controller and signal generator the criterion in such form always depends on initial conditions (states of the plant and controller). To be able to compare the two approaches zero initial conditions in the plant and the controller are considered. The initial conditions of reference generator are given by its output.

The criterion (2) can be written in the following form

$$J = \sum_{k=0}^{\infty} e(k)^2 + r\bar{u}(k)^2 = \langle EE^* \rangle + r\langle \bar{U}\bar{U}^* \rangle, \quad (3)$$

where we used the following notation

$$\begin{aligned} E &= e_0 + e_1d^1 + e_2d^2 + \dots + e_id^i + \dots, \\ E^* &= e_0 + e_1d^{-1} + e_2d^{-2} + \dots + e_id^{-i} + \dots, \end{aligned}$$

and $\langle X \rangle$ is the absolute term of the sequence X written in the form of formal power series $X = \dots + x_{-1}d^{-1} + x_0 + x_1d + \dots$, so $\langle X \rangle = x_0$.

The auxiliary \bar{U} equals $\bar{U} = \frac{sga(f^0)^-}{\Delta f}$. The criterion (2) after the substitution and modification has the form

$$J = \left\langle \frac{g}{f} \frac{g^*}{f^*} \right\rangle - \left\langle \frac{sbg}{f\Delta} \frac{g^*}{f^*} \right\rangle - \left\langle \frac{s^*b^*g^*}{f^*\Delta^*} \frac{g}{f} \right\rangle + \left\langle \frac{sgl}{f\Delta} \frac{s^*g^*l^*}{f^*\Delta^*} \right\rangle, \quad (4)$$

where stable polynomial l is obtained by spectral factorization

$$bb^* + ra_a a_a^* = ll^*. \quad (5)$$

and $a_a = a(f^0)^-$ is augmented plant denominator. Such augmentation appears here only in the formula for spectral factorization and is due to \bar{U} in the criterion.

The minimization of the criterion is done by completing the squares. The criterion after modification has the form

$$J = \left\langle g_1 \left(\frac{sg_s \bar{g}_n l}{\Delta f} - \frac{b^* g_s \bar{g}_n}{l^* f} \right) \left(\frac{sg_s \bar{g}_n l}{\Delta f} - \frac{b^* g_s \bar{g}_n}{l^* f} \right)^* g_1^* \right\rangle + r \left\langle \left(\frac{ga^0}{l(f^0)^+} \right) \left(\frac{ga^0}{l(f^0)^+} \right)^* \right\rangle.$$

where we introduce the following factorization of polynomial $g = g_s g_n g_1$. The polynomials g_s , g_n and g_1 are stable, unstable and on the stability boundary parts of the polynomial g respectively. The polynomial $\bar{g}_n = g_n^* d^\beta$, where β is the order of g_n . So \bar{g}_n is stable polynomial.

The absolute minimum of the criterion with respect to the controller is reached when the first term in the criterion equals zero which results in noncausal controller. To obtain the causal structure it is necessary to provide the decomposition according to the following relation

$$\frac{b^* g_s \bar{g}_n}{l^* f} = \frac{y}{f} + \frac{x^*}{l^*},$$

which results in the equation

$$x^* f + y l^* = b^* g_s \bar{g}_n,$$

To reach the minimum of the criterion the absolute term of the polynomial x^* must equal zero. The minimum of the criterion is reached (with causal controller) when

$$\frac{sg_s \bar{g}_n l}{\Delta f} - \frac{y}{f} = 0. \quad (6)$$

From the equation (6) follows that the numerator s of the controller C_1 equals $s = y$ and the characteristic polynomial equals $\Delta = g_s \bar{g}_n l$ and so the stability and asymptotic tracking is guaranteed. The polynomials q and p of the feedback controller result from the solution of the characteristic equation $ap + bq = \Delta = g_s \bar{g}_n l$.

The minimum of the criterion equals

$$J_{opt} = \left\langle g_1 \frac{x}{l} \frac{x^*}{l^*} (g_1)^* \right\rangle + r \left\langle \left(\frac{ga^0}{l(f^0)^+} \right) \left(\frac{ga^0}{l(f^0)^+} \right)^* \right\rangle, \quad (7)$$

where the second term equals the absolute minimum of the criterion in case of noncausal controller and the first term expresses the augmentation of the criterion due to the causality of the controller.

From the previous solution follows that nonrobust asymptotic tracking structure is standard feedback structure with two degree of freedom, in which during optimization procedure the spectral factorization is realized with augmented denominator $a_a = a(f^0)^-$ of the plant.

4. ROBUST LQ TRACKING

Robust asymptotic reference signal tracking is realized according to Figure 7 with one degree of freedom controller. The controller R consists of two blocks in series. The first block has transfer function $C = \frac{q(d)}{p(d)}$ and its nominator and denominator polynomials $q(d)$ and $p(d)$ respectively will be determined by optimization procedure. The second block with transfer function $1/(f^0)^-$ guarantees asymptotic reference signal tracking. The polynomial f^0 determines the modes of the reference which are not in the plant P and $(f^0)^-$ determines its nonstable part.

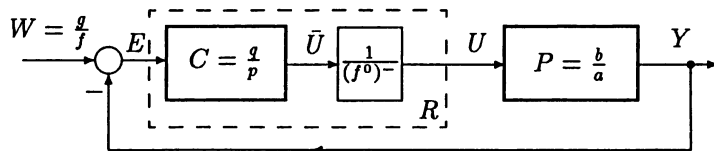

Fig. 7. Robust quadratic optimal reference tracking.

According to Figure 7 the control error equals

$$E(d) = W(d) - Y(d) = \frac{g}{f} - \frac{bqg}{\Delta f} = \frac{a^0 gp}{\Delta(f^0)^+}, \quad (8)$$

where $\Delta = ap(f^0)^- + bq$ is the characteristic polynomial of the feedback structure. The control error is stable for arbitrary reference $W = \frac{g}{f}$ provided the feedback structure is stable. So asymptotic tracking is robust and does not depend on property of the plant.

The control quality is measured by the same quadratic criterion (2) as in the previous case where again the signal \bar{U} is considered in the criterion of control quality (see Figure 7). We are looking for the optimal controller R which minimizes the quadratic criterion (2) which after the substitution can be written in the following form

$$J = \left\langle \frac{g}{f} \frac{g^*}{f^*} \right\rangle - \left\langle \frac{qbg}{f\Delta} \frac{g^*}{f^*} \right\rangle - \left\langle \frac{q^* b^* g^* g}{f^* \Delta^* f} \right\rangle + \left\langle \frac{qgl}{f\Delta} \frac{q^* g^* l^*}{f^* \Delta^*} \right\rangle, \quad (9)$$

where stable polynomial l is obtained by spectral factorization (5). To obtain stable feedback structure it is necessary to modify the last quadratic term in the criterion

(4) in the following way

$$\begin{aligned} \left\langle \frac{qgl q^* g^* l^*}{f\Delta f^* \Delta^*} \right\rangle &= \left\langle \frac{qgl a_{01} a_{0n} q^* g^* l^* (a_{01})^* (a_{0n})^*}{f\Delta a_{01} a_{0n} f^* \Delta^* (a_{01})^* (a_{0n})^*} \right\rangle \\ &= \left\langle g_1 a_{01} \left(\frac{qg_s \bar{g}_n l \bar{a}_{0n}}{f\Delta a_{01} a_{0n}} \right) \left(\frac{qg_s \bar{g}_n l \bar{a}_{n0}}{f\Delta a_{01} a_{0n}} \right)^* a_{01}^* g_1^* \right\rangle, \end{aligned}$$

where we introduce the factorization of polynomials g as described in previous section and also factorization of polynomial $a^0 = a_{0s} a_{0n} a_{01}$. The polynomials a_{0s} , a_{0n} and a_{01} are stable, unstable and on the stability boundary parts of the polynomial a_0 respectively. The polynomial $\bar{a}_{0n} = a_{0n}^* d^\alpha$, where α is the order of a_{0n} . So \bar{a}_{0n} is stable polynomial.

The minimization of the criterion is done by completing the squares

$$\begin{aligned} J &= \left\langle g_1 a_{01} \left(\frac{qlm}{\Delta f a_{01} a_{0n}} - \frac{b^* m}{l^* f a_{01} a_{0n}} \right) \left(\frac{qlm}{\Delta f a_{01} a_{0n}} - \frac{b^* m}{l^* f a_{01} a_{0n}} \right)^* a_{01}^* g_1^* \right\rangle \\ &\quad + r \left\langle \left(\frac{ga^0}{l(f^0)+} \right) \left(\frac{ga^0}{l(f^0)+} \right)^* \right\rangle, \end{aligned} \quad (10)$$

where the stable auxiliary polynomial $m = g_s \bar{g}_n \bar{a}_{0n}$. To obtain the causal control structure it is necessary to provide the decomposition of one term in the previous criterion, so

$$\frac{b^* m}{l^* f a_{01} a_{0n}} = \frac{y}{f a_{01} a_{0n}} + \frac{x^*}{l^*}. \quad (11)$$

From the previous decomposition follows the equation for polynomials x and y

$$x^* f a_{01} a_{0n} + y l^* = b^* m. \quad (12)$$

For minimum of the criterion the absolute term of the polynomial x^* must equal to zero. After the substitution the decomposition (11) to the criterion it is possible to provide the minimization of the criterion with respect to causal controller. The minimum of the criterion is reached when

$$\frac{qml}{\Delta f a_{01} a_{0n}} - \frac{y}{f a_{01} a_{0n}} = 0.$$

Previous condition for causal optimal control can be expressed in the form of polynomial equation

$$qml - y\Delta = 0. \quad (13)$$

The solution $q = ya_{0s}$, and $\Delta = lma_{0s}$, of the previous equation determines the nominator of the controller. Such solution guarantees determination of the denominator of the controller from the equation for the characteristic polynomial of the control structure.

In this way the quality criterion reaches its minimum

$$J_{opt} = \left\langle g_1 a_{01} \frac{x}{l} \frac{x^*}{l^*} a_{01}^* g_1^* \right\rangle + r \left\langle \left(\frac{ga^0}{l(f^0)+} \right) \left(\frac{ga^0}{l(f^0)+} \right)^* \right\rangle, \quad (14)$$

where the second term equals the minimum value of the criterion in the case of noncausal controller and the first term in the criterion expresses the augmentation of the criterion due to the causality of the controller.

The equation (8) can be changed to the polynomial equation by its multiplication by d^α , where α is the order of the plant P . The equation (8) has then the form

$$\bar{x}fa_{01}a_{0n} + y\bar{l} = \bar{b}m, \quad (15)$$

where $\bar{x} = x^*d^\alpha$, $\bar{l} = l^*d^\alpha$ and $\bar{b} = b^*d^\alpha$. Previous equation must be solved for minimum degree of polynomial \bar{x} (to guarantee that absolute term of x^* equals zero).

Robust tracking structure is standard feedback structure with one degree of freedom controller and for the purposes of synthesis with augmented plant $P_a = P \frac{1}{(f^0)^-}$. In reality the term $\frac{1}{(f^0)^-}$ is of course realized in the controller.

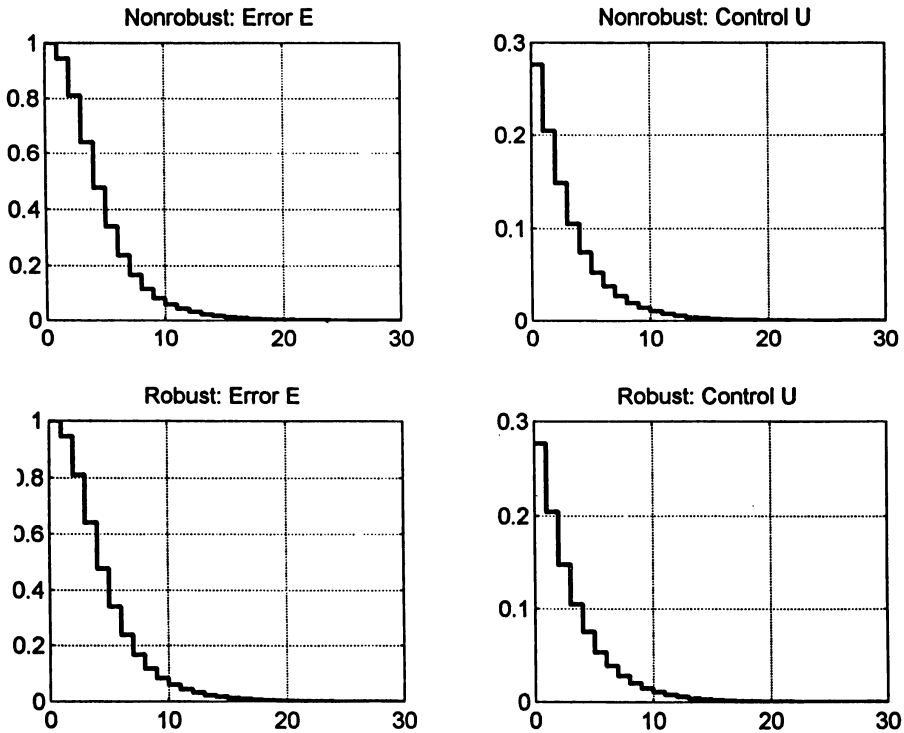

Fig. 8. Robust and nonrobust control of stable system for $\varphi = 40^\circ$, $\xi = 0.766$.

5. SIMULATION RESULTS

Program in MATLAB was realized to simulate optimal control in one and two degree of freedom control structure for arbitrary plant transfer function and arbitrary

reference. Here only results of optimal discrete time control of the continuous system with stable and unstable poles are presented.

Example. Let us have a continuous system with the transfer function

$$G(s) = \frac{1}{s^2 + 2\xi s + 1},$$

where damping factor $\xi = \cos(\varphi) \in (1, -1)$. One degree and two degree of freedom structure give the same results for stable plants. For $\varphi = 40^\circ$, $\xi = 0.766$ the simulation results are shown in Figure 8 (sampling period $T_s = 2\pi/8$ and weight in the criterion $r = 10$).

For unstable plant with $\varphi = 110^\circ$, $\xi = -0.342$ simulation results of control in both structures are presented in Figure 9 (with the same sampling period and the same weight in criterion).

How optimal criterion depends on damping factor $\xi = \cos(\varphi)$ it is shown in Figure 10. For stable plants the results of both control structures are the same, but for unstable plants they differ considerably.

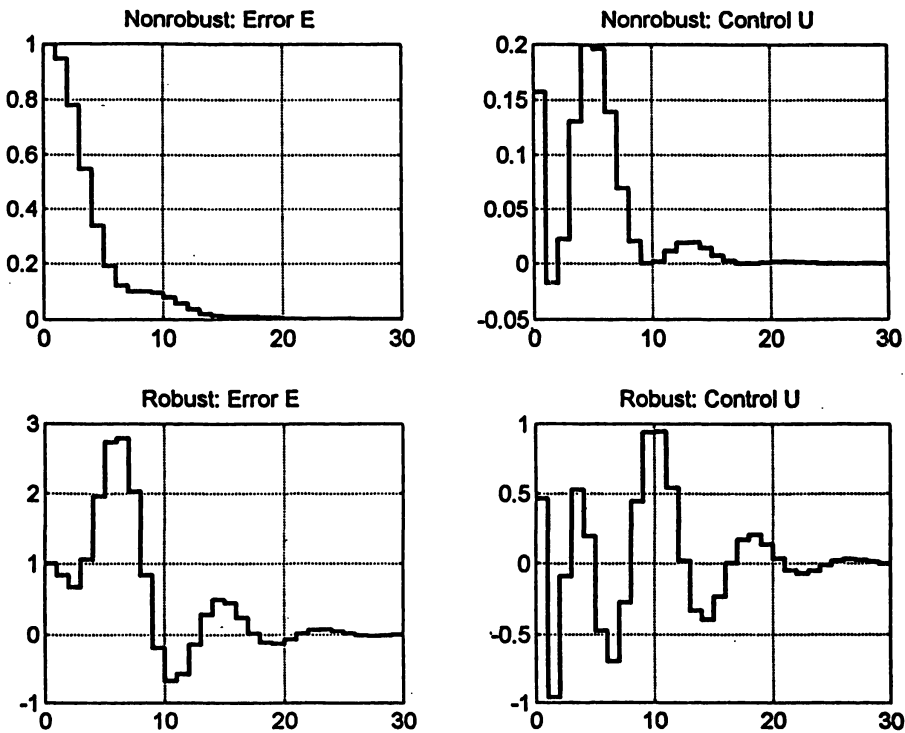

Fig. 9. Robust and nonrobust control of unstable system for $\varphi = 110^\circ$, $\xi = -0.342$.

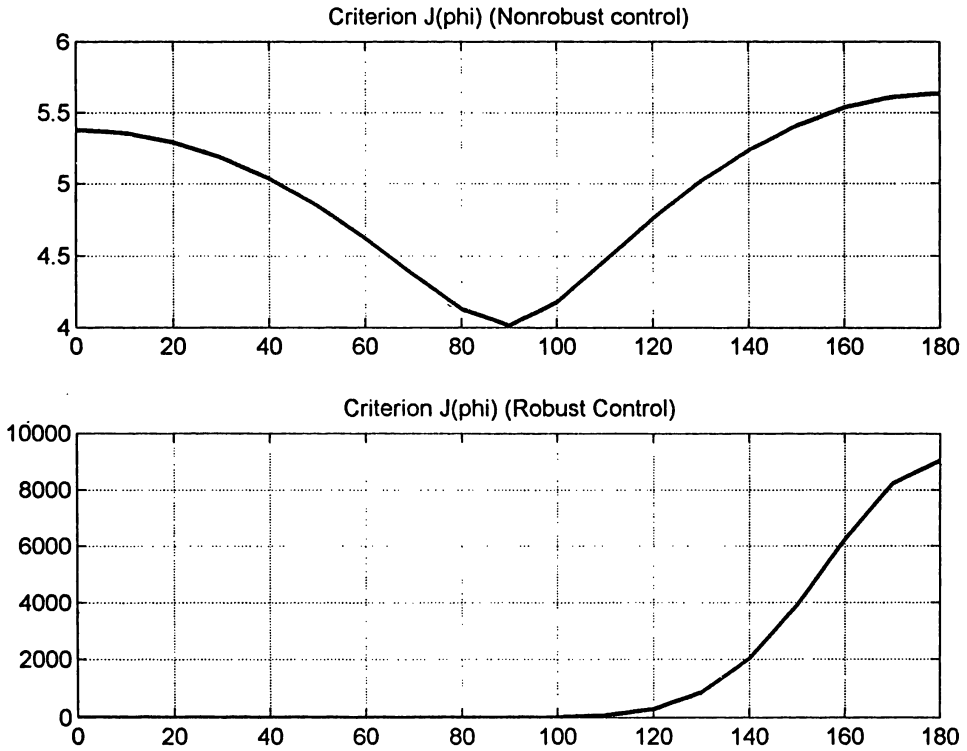

Fig. 10. Robust and nonrobust control – Criterion as a function of damping factor φ .

6. CONCLUSION

From the comparison of the results of robust and nonrobust control structure the following conclusions follow immediately:

- *Quadratic criterion and initial conditions*
Quadratic criterion defined in (2) depends on initial conditions in plant and the controller. So the optimal controllers depend on initial conditions too. To be able to compare the two approaches zero initial conditions are considered.
- *Absolute minimum of quadratic criterion*
Absolute minimum of quadratic criterion is the same in both control structures. Robust control structure with one degree of freedom is unrealizable in this case (feedback loop must be causal) whilst nonrobust control structure with two degree of freedom can have anticipating feedforward part.

- *Stable plants*
For stable plants both structures give the same results and so for stable plants the robust control structure with error driven controller is preferable. It is the reason that error driven controllers are so popular in praxis.
- *Unstable plants*
Only for unstable plants nonrobust control structure gives better performance than the robust structure because one degree of freedom controller must simultaneously stabilize and optimize the whole feedback structure.
- *Robustness of two degree structure*
Even two degree of control structure can be realized as a robust control structure with respect to asymptotic tracking. But robustness is guaranteed only with respect to plant parameters and not to controller parameters.
- *Robustness of one degree structure*
One degree of freedom structure is robust with respect to plant and controller parameters provided the feedback structure remains stable. But unstable modes of the reference must remain fixed in the plant or in the controller.
- *Robustness to all plant parameters*
To guarantee robustness with respect to all plant parameters in one degree of freedom control structure it is necessary, according to internal model principle, to realize the model of the whole unstable part of the reference in the controller (the denominator of the controller must contain polynomial f and not only f^0).
- *Asymptotic reference tracking*
Asymptotic reference tracking in two degree of freedom structure with nonrobust controller is guaranteed without internal model of unstable part of the reference.

(Received October 31, 1996.)

REFERENCES

-
- [1] V. Kučera: Discrete Linear Control: The Polynomial Equation Approach. Wiley, Chichester 1979.
 - [2] H. Kwakernaak and R. Sivan: Linear Optimal Control Systems. Wiley, New York 1972.
 - [3] P. Neuman, P. Husták, J. Štecha and V. Havlena: State controller/observer design for superheater temperature control. In: Proceedings of the 4th IFAC Symposium CADCS'88, Beijing 1988, pp. 168–174.
 - [4] J. Štecha and V. Havlena: Internal model principle and asymptotic reference signal tracking. In: Proceedings of the Cairo Third IASTED International Conference Computer Applications in Industry, Cairo 1994, pp. 107–110.
 - [5] J. Štecha and F. Kraus: Robustness versus control quality in asymptotic reference tracking. In: Proceedings of the Fifteenth IASTED International Conference "Modelling, Identification and Control", Innsbruck 1996, pp. 292–294.
 - [6] M. Vidyasagar: Control System Synthesis: A Factorization Approach. MIT Press, Cambridge, MA 1987.

- [7] V. Kučera: Analysis and Design of Discrete Linear Control Systems. Academia, Prague 1991.

*Prof. Ing. Jan Štecha, CSc., Trnka Laboratory of Automatic Control, Department of Automatic Control, Faculty of Electrical Engineering, Czech Technical University, Karlovo nám. 13, 121 35 Praha 2. Czech Republic.
e-mail: stech@control.felk.cvut.cz*